

## APPENDIX B

### Comprehensive Vehicle Inspection Report

**Customer Details**

Exeter Motor Works  
Old Tiverton Road  
Exeter

**Report Date:** 10/02/2017

**Report No:** 10136

**Customer's contact details**

**Home:**

**Work:** 01392 210739

**Mobile:** 07810825111

**VEHICLE DETAILS**

**Make** VOLKSWAGEN

**Registration Number** NK10 CYV

**Model** CADDY MAXI LIFE TDI

**Colour** SILVER

**Vehicle Identity Number (VIN)**

WV2ZZZ2KZAX097106

**VIN Checked and confirmed  
on vehicle**  
Yes X No

**V5/Registration document  
available and checked** No

**MOT Certificate available and  
checked** YES

**Mileage reading** In 69454  
(Not guaranteed) Out 69451

**MOT Expiry Date** 09/02/18

**Vehicle Excise Licence Expiry** 01/01/18

**Date of inspection** 10/02//2017

**Time of inspection** 13:00

**Location of vehicle** Exeter Motor Works, Old Tiverton Road, Exeter.

**Lighting** Good

**Weather.** Good  
(See notes)

**Ramp available.** Yes  No   
(See notes)

**SECURITY CHECK**

The vehicle identification number on this vehicle was checked and found to be **consistent** with the manufacturer's format.

**SUMMARY REPORT**

X **READY FOR USE** – No faults found, suitable for immediate use.

**ADVISABLE REPAIRS ONLY** – Suitable for immediate use but advisable repairs should be planned for.

**ESSENTIAL AND ADVISABLE REPAIRS REQUIRED** – Not suitable unless all essential repairs are undertaken and advisable repairs, if any are planned for.

**UNSATISFACTORY** – Vehicle has significant deficiencies, which are judged to be impractical or uneconomical to repair to a satisfactory standard.

Please read all pages of this report

**KEY:**

- S satisfactory
- R repainted
- = scratch
- X dent
- O corrosion
- C chip / rust
- P previous repairs

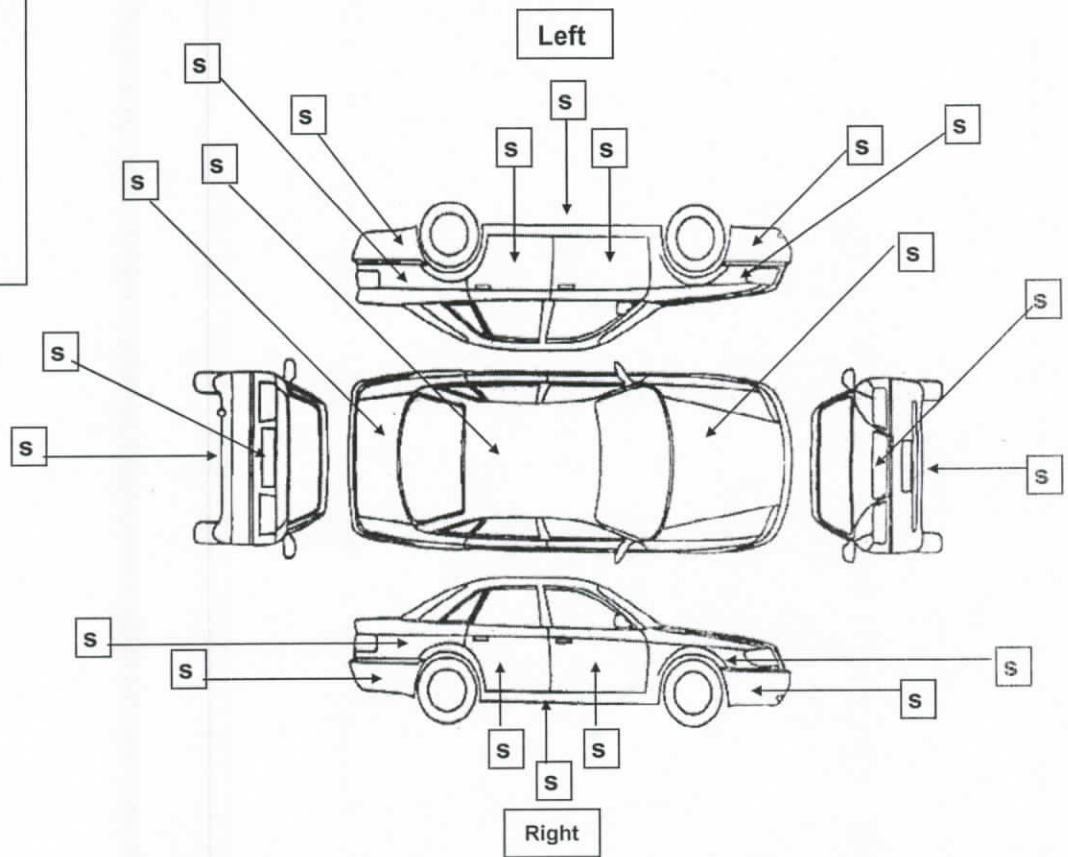

Minor blemishes, which are acceptable fair wear and tear for the vehicle's age, recorded mileage and type, are not recorded and you should satisfy yourself in this regard.

<b>EVIDENCE OF BODYWORK REPAIRS</b>	Yes	No X
<b>BODYWORK CLEAN AND DRY</b>	Yes X	No (See Notes)

**Comments**

The exterior body condition was good and commensurate with the vehicles age and recorded mileage.

**KEY FOR POINTS ON FOLLOWING PAGES**

- S Satisfactory for age and recorded mileage
  - Could not be checked
  - x Essential repair requiring immediate attention
  - A Advisable repair should be considered prior to purchase
  - N/A Not applicable
  - Y Yes
  - N No
- Please note: Right = Off side (O/S) and Left = Near side (N/S) as viewed from the driver's seat.



**BODY EXTERIOR**

1. Panel Condition / alignment	S	6. Door locks - operation	S	11. Mud flaps	S
2. Paintwork	S	7. Fuel filler cover and cap	S	12. Body panels	S
3. Exterior trim / grille	S	8. Soft top / Hard top (operation)	N/A	13. Bonnet catch	S
4. Glass	S	9. Body damage	A	14. Bonnet hinges	S
5. Bumpers / No plates – Ft / Rr	S	10. Corrosion	No	No	

**ENGINE COMPARTMENT****PETROL****DIESEL****MULTI-FUEL****No. of CYLINDERS: 4**

15. Coolant Level / Condition	S	22. Power Steering – oil level	S	29. Turbo / supercharger	--
16. Coolant leaks	No	23. Clutch Fluid	S	30. Fuel pump / pipes	S
17. Antifreeze *	S	24. Brake Fluid	S	31. Accelerator linkage	S
18. Radiator / Cap	S	25. Engine Oil level	S	32. Cold starting	--
19. Hoses / Pipes	S	26. External leaks (upper engine)	S	33. Fast idle (cold)	--
20. Drive Belts	--	27. Engine mountings	S	34. Noise level (cold)	--
21. Water Pump (Not visible)	--	28. Fuel Injection	S	35. Excess fumes / smoke	No

**Note** - To ensure future serviceability, it is important that the engine camshaft belt is replaced at intervals specified by the manufacturer. It is in your best interests you ensure that this is carried out. \* Antifreeze only has a 2/3 year life span and requires its strength adjusting after this time or replacing as per manufacturers specifications.

**ELECTRICAL / CONTROLS**

36. Starting system / Ignition lock	S	41. Rear lights & No. plate lights	S	49. Instruments	S
37. Battery condition	S	42. Stop lights	S	50. Horn	S
38. Battery voltages:	S	43. Indicator/ Hazard lights	S	51. Radio/Cass/CD/Aerial	S
- Normal 13.11 volts	S	44. Reverse / Fog lights	S	52. Heater / Fan controls	S
- Starting 10.07 volts	S	45. Auxilliary lights	N/A	53. Air Con operation	S
- Charging 14.32 volts	S	46. Interior / Panel lights	S	54. Windows / Sun roof	S
39. Headlights	S	47. Mirrors (electric)	S	55. Wipers / Washers	S
40. Sidelights / running lights	S	48. Controls / Switches	S	56. Headlamp wash / wipe	N/A

**Note** - We are unable to verify dash panel light and switch back lighting operation due to the daylight conditions. Please note that switching them "on or off" only assesses electrical components. Accuracy of instruments cannot be assessed.

**INTERIOR / LUGGAGE COMPARTMENT****NUMBER OF SEATS: 5**

57. Steering Wheel / Adjustment	S	64. Door seals / hinges	S	71. Rear parcel shelf / load cover	--
58. Seat upholstery	S	65. Interior sills	S	72. Boot / tailgate lock	S
59. Seat adjustment	S	66. Headlining / visors	S	73. Luggage area trim con	S
60. Seatbelts	S	67. Sun roof	N/A	74. Illumination light	S
61. Carpets / Mats	S	68. Dash panel (condition)	S	75. Tool kit	S
62. Door trim panels	S	69. Cigarette lighter	N/A	76. Hard / Soft top (condition)	N/A
63. Door fittings / operation	S	70. Mirrors (internal)	S	77. Tonneau cover	N/A

**FRONT SUSPENSION / STEERING / UNDER FRAME**

78. Engine underside leakage	No	83. Wheel hubs / bearings	S	88. Sub-frames mountings	S
79. Steering joints/ ball joints	S	84. Springs/suspension units	S	89. Suspension arms / mountings	S
80. Steering rack / box	S	85. Pipes / hoses	S	90. Tie bars / anti roll bars	S
81. Chassis members	S	86. Dampers (condition / leaks)	S	91. Corrosion protection	Yes
82. Power steering (operation)	S	87. Gaiters	S	92. Corrosion – floor/chassis	No

**REAR SUSPENSION / UNDER FRAME**

93. Springs/suspension bars	S	97. Location rods/fixings	N/A	101. Sub-frames/ mountings	S
94. Anti roll bar	S	98. Bump stops/gaiters	N/A	102. Chassis members	S
95. Dampers/bushes	S	99. Wheel hubs/bearings	S	103. Corrosion protection	Yes
96. Suspension arms/fixings	N/A	100. Pipes/hoses	N/A	104. Corrosion – floor/chassis	No

**CLUTCH / TRANSMISSION****MANUAL** **AUTOMATIC****MULTI-USE / 4x4**

105. Fluid / oil leaks	No	109. Casings	S	113. Backlash	S
106. Cables / adjustments	N/A	110. Mountings	S	114. Gaiters	S
107. Hydraulic system	S	111. Drive shaft assembly	S	115. Propshaft(s) / fittings	N/A
108. Linkage (wear)	S	112. Universal / sliding joints	S	116. Bearings / supports	N/A





## Vehicle documents and Inspection environment notes.

Engineer Indicate with "X" as applicable.

### Registration Document (V5):

- No registration document was seen with the vehicle and you are advised to satisfy yourself that the vehicle identification number and engine number (where quoted) correspond to those shown on this report. Warning: **DO NOT BUY ANY VEHICLE WITHOUT A V5.**
- The V5/Registration Document shows \_\_\_\_\_ previous keeper(s), the last change of Keeper on \_\_\_\_\_.

### Security:

- The Master Key was not available. Please ensure this is supplied if the vehicle is purchased.
- The engineer recommends that relevant spare and service keys be obtained prior to purchase.
- Obtain hand books and radio codes for vehicle prior to purchase as these were not seen in the vehicle.

### M O T:

- As only a small amount of time is left on the MOT Certificate (less than 3 months) the engineer recommends a full year's MOT be obtained prior to purchase.
- A Full Year MOT Certificate has been seen with the vehicle.

### Servicing:

- The service history seen, indicated that the last recorded service was carried out at \_\_\_\_\_ miles. No immediate servicing is necessary. Next service is due as per manufacturer's recommendations or as per the Vehicles Service indicator.
- The service history seen, indicated that the last recorded service was carried out on the \_\_\_\_\_ at \_\_\_\_\_ miles. Therefore the engineer would suggest a full service and brake inspection to the manufacturer recommendations prior to purchase, which may reveal further defects not apparent at this examination.
- No service documentation seen with this vehicle and therefore the engineer would recommend a full service and brake inspection to the manufacturer's recommendations prior to purchase, which may reveal further defects not apparent at this examination.

### Inspection conditions notes:

- No vehicle hoist/ramp was available. A large trolley jack and stands were used in order to carry out underside checks. This limits the view of the underside. Some areas could not be fully seen. There *may* be further defects, which may be visible given clear access and view.
- The body/paintwork was wet/dirty/dusty this severely restricts inspection of the paintwork. Please note that there may be other defects present, which were not visible due to the obscured paintwork, but which may become visible once dry and clean.

## Engineers Comments

The vehicle is considered overall to be a fair and reasonable example of the type, being in a generally reasonable condition and generally considered to be consistent with the type for the age and indicated recorded mileage in most areas.

The items listed as "could not be checked" (---) normally indicate items were obscured by covers/shields or other equipment.

The Water pump – Engine drive belt/chain - these items could not been fully examined, as covers, trims and other equipment obscure them.

The cooling system was pressure tested to 0.7 bars, no pressure loss was noted on the system or pressure cap. The antifreeze concentration was acceptable, but has deteriorated from its original strength and at the next routine service may need to be refreshed/replaced. It is advised that the coolant strength be checked again at the next routine service. Antifreeze only has a 2/3-year life and requires its strength adjusting after this time or replacing as per manufacturer's specifications.

The vehicle is fitted with vented front brake disc and pads, supported at the rear by a single arrangement. Although the visible brakes only show some signs of general serviceable wear, some deterioration is noted, which will need attention in the near future. It is strongly advised to remove all road wheels and examine the inner brake components, which are obscured on this vehicle prior to purchase, replacing any worn or badly corroded parts. It is probable that the front brakes at least, will need to be replaced at the next routine service.

The steering & suspension has been assessed to MOT standard. This allows for a degree of wear and deterioration of components without rendering them unserviceable. The extent of wear is not considered excessive at this juncture and unlikely to attract MOT failure.

The road test distance and or top speed was limited due to the general area/inspection location, and/or traffic levels and/or adverse weather conditions and/or lack of fuel when the vehicle was tested and driven. Comment cannot be made in these instances in relation to possible "high speed" or "sustained speed," related driving defects, which may become apparent at a later stage after any purchase due to these limiting conditions.

## Essential Repairs

It is strongly advised that the essential defects are investigated and rectified prior to purchase.

Item	Comment
<b>Additional Comments</b>	
No vehicle hoist/ramp was available. A large trolley jack and stands were used in order to carry out underside checks. This limits the view of the underside somewhat. Some areas could not be fully seen. There may be further defects, which may be visible given clear underside access and view.	
The exhaust has been identified, as having limited life because, although there is no leakage present, there is some external corrosion present and the inside of the system, which may have significant deterioration, cannot be inspected internally.	
Please note that a service is recommended, this may reveal repairs or maintenance requirements that could not be identified due to the constraints of a visual and external examination of the vehicle carried out without the benefit of a vehicle hoist.	

### Additional Comments

No vehicle hoist/ramp was available. A large trolley jack and stands were used in order to carry out underside checks. This limits the view of the underside somewhat. Some areas could not be fully seen. There may be further defects, which may be visible given clear underside access and view.

The exhaust has been identified, as having limited life because, although there is no leakage present, there is some external corrosion present and the inside of the system, which may have significant deterioration, cannot be inspected internally.

Please note that a service is recommended, this may reveal repairs or maintenance requirements that could not be identified due to the constraints of a visual and external examination of the vehicle carried out without the benefit of a vehicle hoist.

Report No: 10136